



DX-BT24-T

MODULE SPECIFICATION

Version: 2.2

Date: 2022-01-06





Update record

Version	Date	Illustrate	Author
V2.1	2018/10/1	initial version	DL
V2.2	2022/01/06	new version	DL

Contact Us

Shenzhen DX-SMART Technology Co., Ltd.

Email: sales@szdx-smart.com

Tel: 0755-29978125

Web: www.szdx-smart.com

Add: Room 601, Block A1, Huafeng Zhigu, Hangkong Road, Baoan District, Shenzhen



Contents

1. Introduction	- 5 -
1.1. Overview	- 5 -
1.2. Key Features	- 5 -
1.3. Application	- 5 -
1.4. Block Diagram	- 6 -
1.5. Basic Parameters	- 6 -
2. Application Interface	- 7 -
2.1. Module Pin Definition	- 7 -
2.2. Pin Definition Description	- 8 -
2.3. Operating Mode	- 9 -
2.4. Energy-saving Mode	- 9 -
2.4.1. Low Power Mode	- 9 -
2.4.2. Hibernation Mode	- 10 -
2.5. Power Design	- 10 -
2.5.1. Power Interface	- 10 -
2.5.2. Power Supply Stability Requirements	- 11 -
2.5.3. Power Down Requirements	- 11 -
2.5.4. RST Reset Pin Description	- 12 -
2.5.5. KEY Pin Definition	- 13 -
2.6. Hardware Physical Interface	- 14 -
2.6.1. UART Interface	- 14 -
2.6.2. Universal Digital IO Port	- 15 -
2.6.3. I2C Interface	- 15 -
2.6.4. SPI Interface	- 16 -
2.6.5. Analog-to-digital Converter (ADC)	- 16 -
2.7. Reference Connection Circuit	- 17 -
3. Electrical Characteristics & Reliability	- 18 -
3.1. Maximum Rating	- 18 -
3.2. Working And Storage Temperature	- 18 -
3.3. Power Consumption	- 19 -
3.4. RF Characteristics	- 19 -
3.5. Static Protection	- 19 -
4. Mechanical Size And Layout Recommendations	- 20 -
4.1. Module Mechanical Size	- 20 -
4.2. Recommend Encapsulation	- 21 -
4.3. Module Top View & Bottom View	- 21 -
4.4. Hardware Design Layout Recommendations	- 22 -
5. Patch Requirements	- 23 -
5.1. Storage Conditions	- 23 -
5.2. Module Baking Treatment	- 23 -



5.3. Reflow Soldering	- 24 -
5.4. Packing Specification	- 25 -

Table index

Table 1 : Basic parameter table	- 6 -
Table 2 : Pin definition description table	- 8 -
Table 3 : Work mode table	- 9 -
Table 4 : Power interface pin definition table	- 10 -
Table 5 : RST pin definition table	- 12 -
Table 6 : RST pin definition	- 12 -
Table 7 : KEY Pin definition table	- 13 -
Table 8 : KEY pin function definition table	- 13 -
Table 9 : Absolute maximum rating table	- 18 -
Table 10 : Working voltage table	- 18 -
Table 11 : Working and storage temperature table	- 18 -
Table 12 : Power consumption table	- 19 -
Table 13 : RF characteristics table	- 19 -
Table 14 : Table of ESD withstand voltage of module pins	- 20 -
Table 15 : Recommended reflow soldering temperature	- 25 -

Picture index

Figure 1 : Functional block diagram	- 6 -
Figure 2 : Module pin definition	- 7 -
Figure 3 : Energy-saving mode control diagram	- 10 -
Figure 4 : Burst transmission power supply requirements	- 11 -
Figure 5 : powered reference circuit	- 11 -
Figure 6 : Reset reference circuit	- 12 -
Figure 7 : Key reset reference circuit	- 12 -
Figure 8 : Open-collector drive wake-up reference circuit	- 13 -
Figure 9 : Key reset reference circuit	- 14 -
Figure 10 : IIC communication sequence diagram	- 15 -
Figure 11 : SPI communication timing diagram	- 16 -
Figure 12 : Typical application circuit	- 17 -
Figure 13 : Reference circuit for serial port level conversion	- 17 -
Figure 14 : Module top and side dimension drawing	- 20 -
Figure 15 : Bottom view size of the module	- 21 -
Figure 16 : Recommended package dimensions	- 21 -
Figure 17 : Top and bottom views of the module	- 21 -
Figure 18 : Reference position for module placement	- 22 -
Figure 19 : Recommended reflow soldering temperature profile	- 25 -
Figure 20 : Pallet size (unit: mm)	- 26 -
Figure 21 : Packing box size (unit: mm)	- 26 -



1. Introduction

1.1. Overview

DX-BT24-T Bluetooth module is built by Shenzhen DX-SMART Technology Co., Ltd. for intelligent wireless data transmission, It uses the DIALOG 14531 chip and follows the Bluetooth BLE 5.1 specification. Support AT commands, users can query and modify the corresponding parameters according to their needs, flexible to use. This module supports UART,SPI, I2C and other interfaces, supports IO port control, ADC acquisition, It has the advantages of ultra-small size, low cost, low power consumption, high receiving sensitivity, etc. Only a few peripheral components are required to realize its powerful functions, and various projects can be customized and developed according to customer needs.

1.2. Key Features

- DIALOG 14531 main control chip
- Bluetooth BLE 5.1
- Power consumption can be as low as 2 uA
- Open distance 45M
- Transmission rate 10K Byte/s
- Ceramic Antenna
- Working temperature -40-+80 °C
- Support UART, IIC,SPI,GPIO hardware interface
- Optional iBeacon mode program
- Optional direct drive mode program

1.3. Application

- Smart home
- Smart education equipment
- Medical equipment monitoring and wireless control
- Measurement and monitoring system



- Industrial sensors and controls
- Tracking and positioning

1.4. Block Diagram

The following figure shows the functional block diagram of the DX-BT24-T Bluetooth module, Explains the following main functions:

- Power section
- Baseband part
- Memory
- RF part
- Peripheral interface

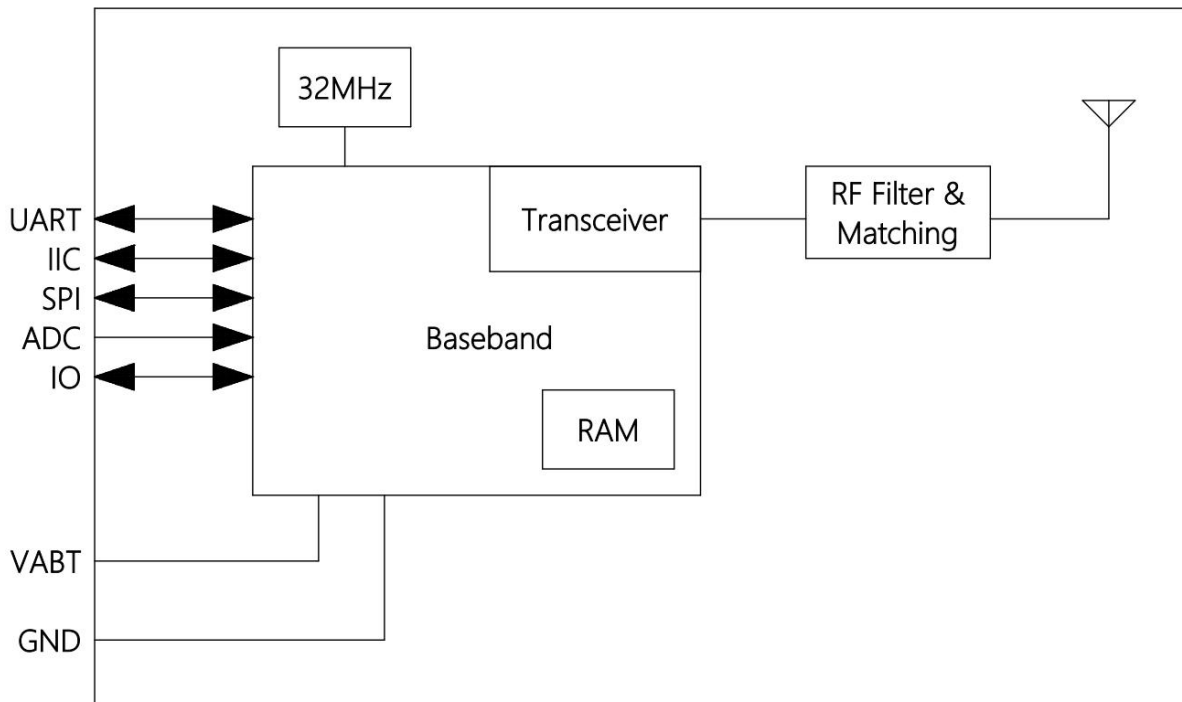

Figure 1: Functional block diagram

1.5. Basic Parameters

Table 1: Basic parameter table

Parameter	Details	Parameter	Details
Chip model	DA14531	Module model	DX-BT24-T
Bluetooth specifications	BLE 5.1	Module size	8.3(L) x7.6 (W) x 2.1(H) mm

Operating Voltage	3.3V	Working current	270 uA
protocol	GATT, ATT, GAP	MTU value	253 bytes
Sensitivity	-94dBm@0.1%BER	Transmit power	-19.5~+2.5dBm
Modulation	GFSK	Frequency band	2.402GHz -2.480GHz ISM band
RF input impedance	50Ω	Frequency hopping and channel	1600hops/s 2MHz space 40 channels
Antenna interface	Onboard antenna / external antenna (optional)	Hardware interface	UART I2C SPI GPIO
Operating temperature	MIN:-40°C - MAX:+85°C	Humidity	10%-95% non-condensing

2. Application Interface

2.1. Module Pin Definition

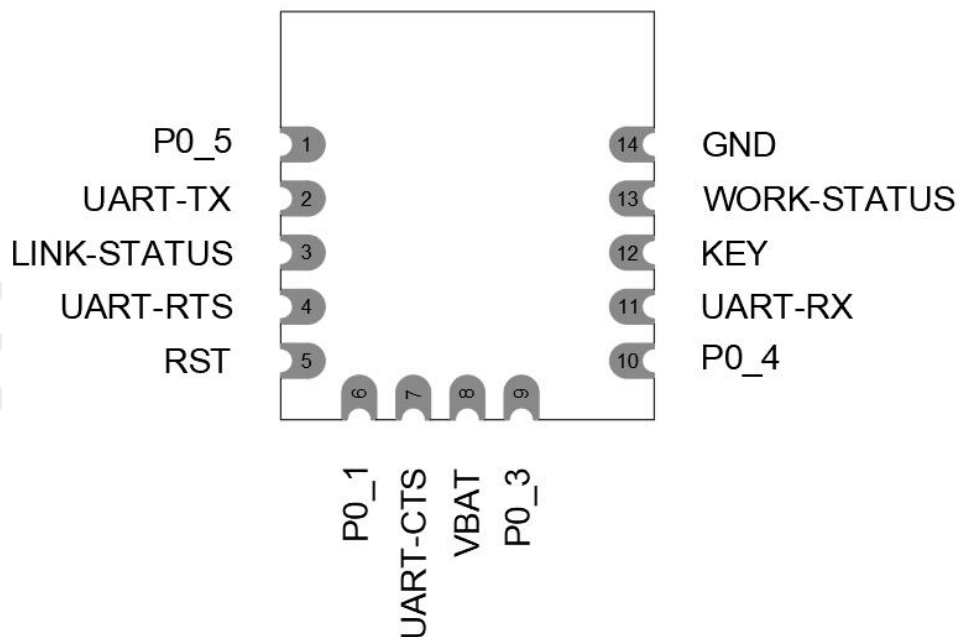

Figure 2: Module pin definition



2.2. Pin Definition Description

Table 2: Pin definition description table

Pin number	Pin name	Pin function	illustrate
1	P0_5	Programmable input/output line	
2	UART-TX	Serial data output	
3	LINK-STATUS	Bluetooth connection status pin	Not connected: Output low level Connection Status: Output high level
4	UART-RTS	UART request to send, active low	
5	RST	Reset Wake up from hibernation mode	For details, please refer to 2.5.4
6	P0_1	Programmable input/output line	
7	UART-CTS	UART clear to send, active low	
8	VBAT	Power input pin	3.3V(Typical value)
9	P0_3	Programmable input/output line	
10	P0_4	Programmable input/output line	
11	UART-RX	Serial data input	
12	KEY	Disconnect pin	For details, please refer to 2.5.5
		Low power mode wake up	For details, please refer to 2.5.5
		Enter pairing mode	For details, please refer to 2.5.5
13	WORK-STATUS	Module working status pin	Not connected: 1s high 1s low Connection Status: 3s high 50ms low Always low in low power consumption and hibernation mode
14	GND	Power Ground	



2.3. Operating Mode

Table 3: Work mode table

mode	Function
Normal working mode	All functions and peripheral interfaces can be used normally
Low power mode	When not connected, Only open broadcast, all peripheral interfaces are closed In the connected state, all functions and peripheral interfaces can be used normally
Hibernation mode	All running RAM blocks of the module are closed, and only the tick clock inside the chip is reserved for wake-up. Broadcasting and all peripheral interfaces are closed

2.4. Energy-saving Mode

2.4.1. Low Power Mode

When the host and the module are connected through the serial port, the module can enter the low power consumption mode through the following steps;

- Use AT+PWRM command to enable low power consumption function. For more information about AT commands, Please refer to "DX-BT24-M&BT24-T Bluetooth Module_Serial UART_Application Guide".
- In low power consumption mode, the module can be found and connected.
- Send a 200ms low-level pulse to the 12-pin KEY of the module to wake up the module to normal working mode.
- To enter low power mode again:
When connected: disconnected, the module automatically enters low power consumption mode;
When it is not connected after waking up: You need to send the AT+PWRM command again to enter the low power consumption mode or reset, power off and restart to enter.
- For hardware, please refer to 2.5.5 wake-up circuit below.

2.4.2. Hibernation Mode

When the host and the module are connected through the serial port, the module can enter the hibernation mode through the following steps;

- Use the AT+PWRM command to enable the hibernation function. For detailed information about the AT command, Please refer to "DX-BT24-M&BT24-T Bluetooth Module_Serial UART_Application Guide".
- In hibernation mode, the module cannot be found and connected.
- Send a 200ms low-level pulse to the 5-pin reset pin to reset and wake up the module to normal working mode.
- After waking up, if you need to enter the hibernation mode again, you need to send the AT+PWRM command;
- For hardware, please refer to 2.5.4 reset circuit below.

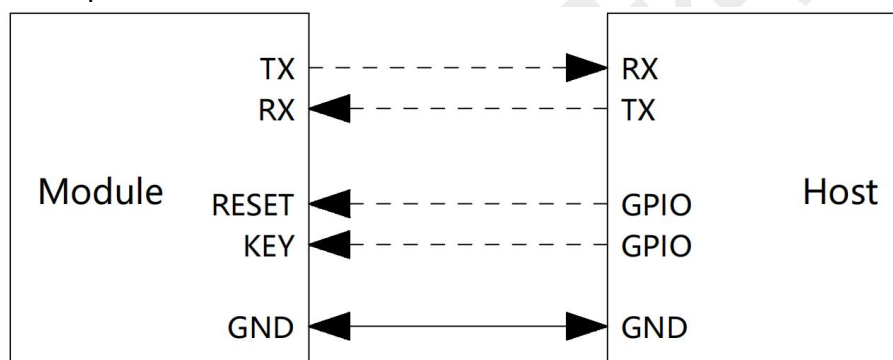

Figure 3: Energy-saving mode control diagram

2.5. Power Design

2.5.1. Power Interface

Power interface pin definition

Table 4: Power interface pin definition table

Pin name	Pin number	describe	Minimum	Typical value	Max	unit
VBAT	8	Module power	2.8	3.3	3.6	V
GND	14	Land	-	0	-	V

2.5.2. Power Supply Stability Requirements

The power supply range of DX-BT24-T is 2.8~3.6V. It is necessary to ensure that the input voltage is not lower than 2.8V. The following figure shows the voltage drop of VBAT during radio frequency burst transmission.

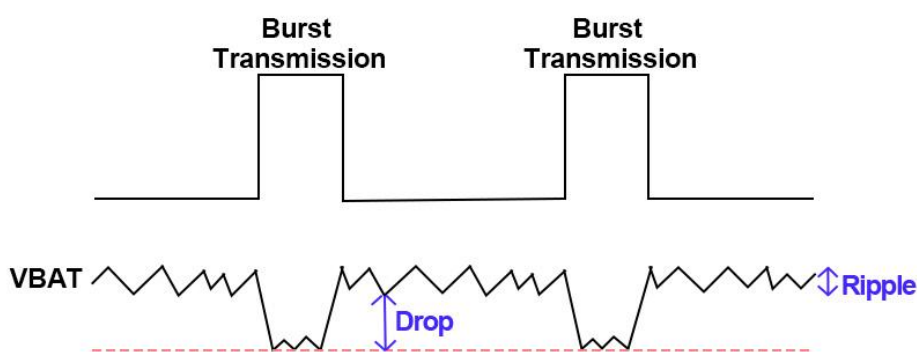

Figure 4: Burst transmission power supply requirements

In order to reduce the voltage drop, it is recommended to reserve 2 (22uF, 0.1uF) chip multilayer ceramic capacitors (MLCC) with the best ESR performance for VBAT, and the capacitors should be placed close to the VBAT pin. The reference circuit is as follows:

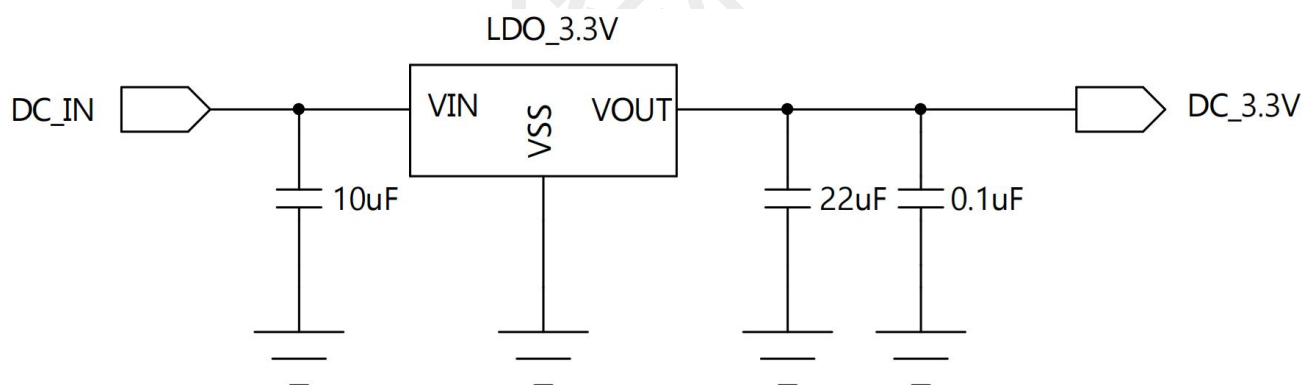

Figure 5: powered reference circuit

2.5.3. Power Down Requirements

Since the working current of the chip of this module is very low, when the power is disconnected, if the IO port of the peripheral MCU has a weak current supplying the module, the module is likely to be in an abnormal working state at this time, so after disconnecting the power of the module, the MCU is connected to the module All IO ports must be configured as pull-down.



2.5.4. RST Reset Pin Description

Table 5: RST pin definition table

Pin name	Pin number	I/O	describe	Remark
RST	5	DI	Module reset	Active high ; NC if not used

Table 6: RST pin definition

Module status	Method of operation	Result
Hibernation	Pull the reset pin high for at least 200ms and release it	Reset wake
Other status	Pull the reset pin high for at least 200ms and release it	Reset

Remark

The RST signal is more sensitive to interference, so it is recommended that the trace should be as short as possible, and it needs to be handled with ground.

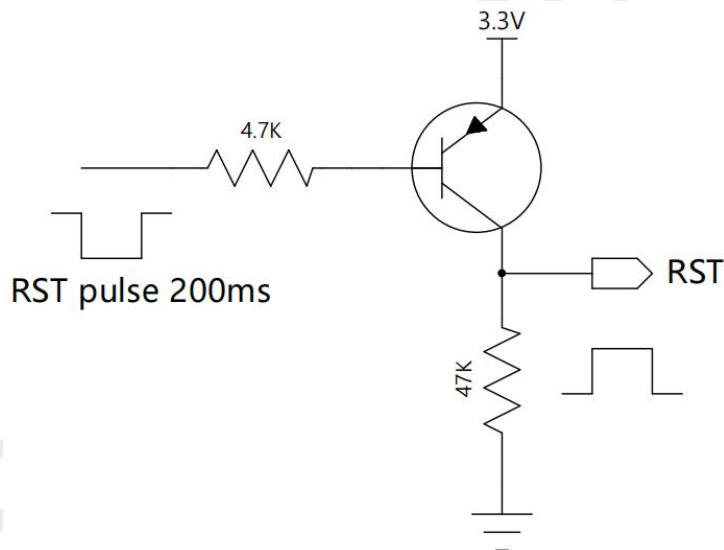

Figure 6: Reset reference circuit

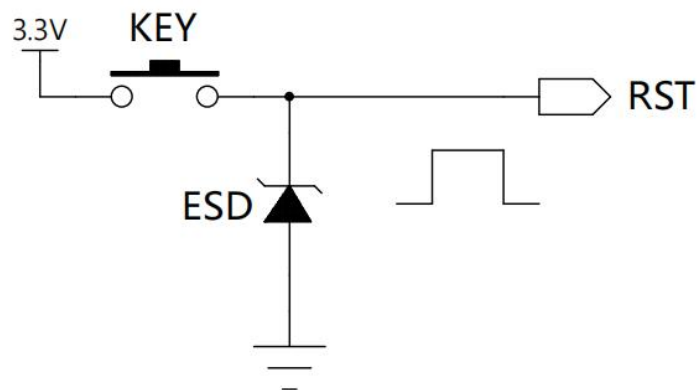

Figure 7: Key reset reference circuit



2.5.5. KEY Pin Definition

Table 7: KEY Pin definition table

Pin name	Pin number	I/O	describe	Remark
KEY	12	DI		

Table 8: KEY pin function definition table

State	Method of operation	result
Connection Status	Pull down the KEY pin for at least 200ms and then release	disconnect
Low power state	Pull down the KEY pin for at least 200ms and then release	wake
standby mode	Pull the KEY pin low for at least 100ms (can be released after being connected)	pairing mode

Remark

Pairing mode: After the slave module enters pairing mode, after the search mode of the master module is set to pairing mode, the master module will automatically connect to the slave module. This pairing mode is only valid for our main module.

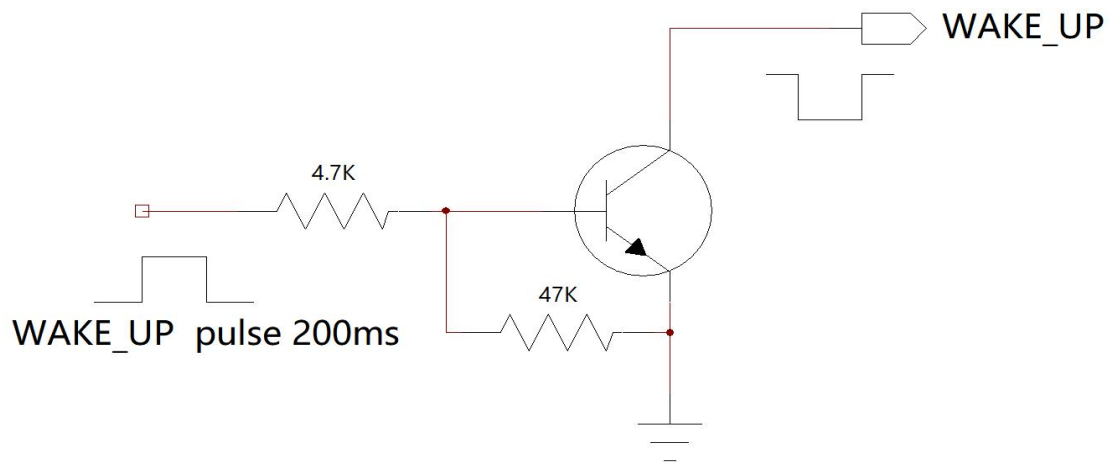

Figure 8: Open-collector drive wake-up reference circuit

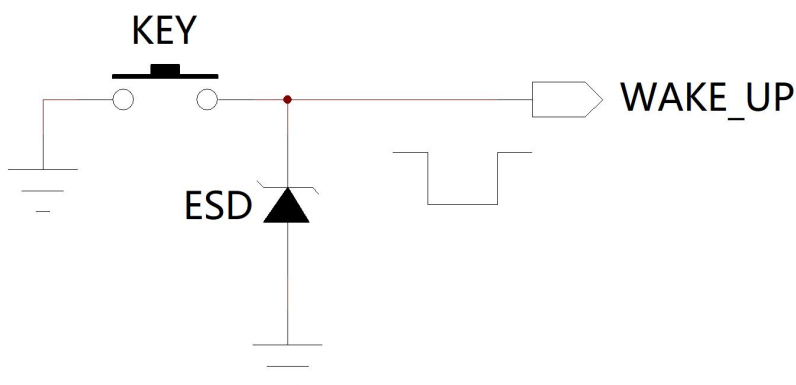

Figure 9: Key reset reference circuit

2.6. Hardware Physical Interface

2.6.1. UART Interface

Four signal pins are used to realize UART function. When DX-BT24-T is connected to another digital device, UART_RX and UART_TX transfer data between the two devices. The remaining two pins, UART_CTS and UART_RTS, can be used to implement RS232 hardware flow control, and they are both active at low level, that is, transmission is allowed at low level, and transmission is stopped at high level.

Possible UART settings

parameter	probable value	
BAUD	minimum	2400baud ($\leq 1\%$ Error)
	standard	9600baud ($\leq 1\%$ Error)
	maximum	115200baud ($\leq 1\%$ Error)
flow control	RTS/CTS, or none	
Parity check	None, odd or even	
Number of stop bits	1/2	
Number of bits per channel	8	



2.6.2. Universal Digital IO Port

Five general digital IO ports are defined in the module. All these IO ports can be configured through software to realize various functions, such as button control, LED drive or interrupt signal of the main controller, etc. Keep floating when not in use

2.6.3. I2C Interface

- Two-wire I2C serial interface composed of serial data line (SDA) and serial clock (SCL)
- Support two speeds

standard mode 0-100Kbit/s

Fast mode $\leq 400\text{Kbit/s}$

- 32-position sending and receiving FIFO depth (32x8-bit Rx & 32x 10-bit Tx)
- Support 7-bit and 10-bit addressing mode and regular call addressing mode.

The I2C interface is an internal circuit that allows communication with an external I2C interface. The external I2C interface is an industry standard two-wire serial interface for connecting external hardware. These two serial lines are called serial data line (SDA) and serial clock line (SCL). The I2C module provides two data transmission rates: 100kHz in standard mode and 400kHz in fast mode. The I2C module also has an arbitration detection function to prevent multiple hosts from attempting to transmit data to the I2C bus at the same time.

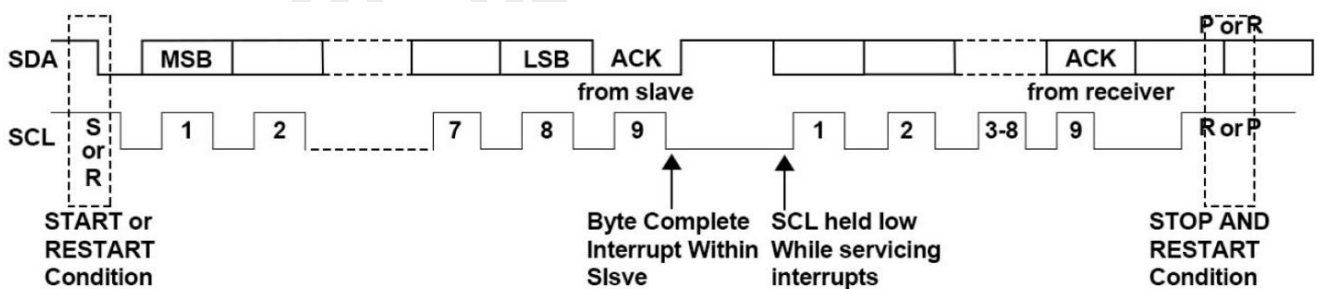

Figure 10: IIC communication sequence diagram

2.6.4. SPI Interface

- Master and slave mode
- From 4bit to 32bit operation
- Main clock up to 32MHz
- Support DMA

This controller implements serial peripheral interface (SPI™) in master-slave mode. The serial interface can transmit and receive from 4-bit to 32-bit in master/slave mode. The controller includes separate TX and RXFIFOs and DMA handshake support. From the mode clock speed is independent of the system clock speed. In addition, the master clock speed can be as fast as the system clock speed. The controller can generate an interrupt when X or RXFIFOs reach the data threshold.

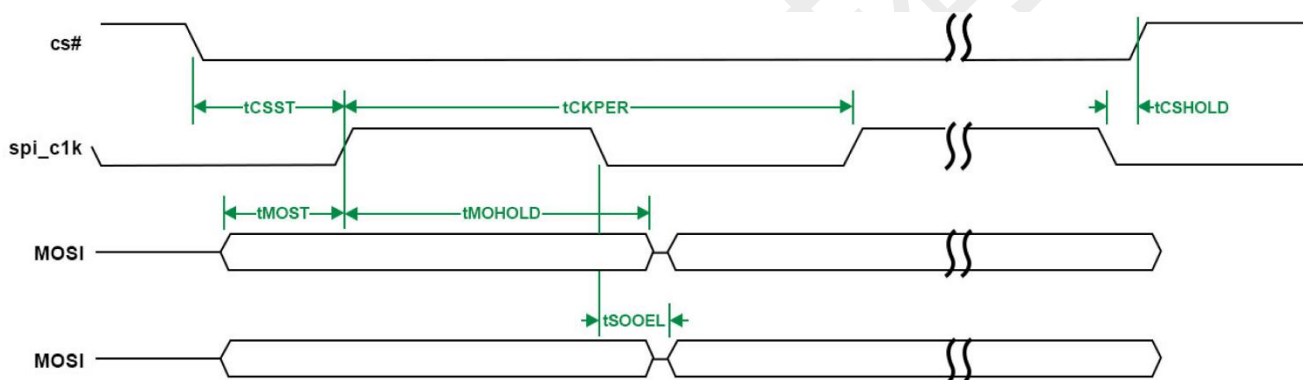

Figure 11: SPI communication timing diagram

2.6.5. Analog-to-digital Converter (ADC)

- Typical 10-bit dynamic ADC of 125 ns
- Maximum sampling rate was 1 Msample/s
- Ultra-low power consumption (20 uA Typical power supply current, 100 ksamples/s)
- Configurable attenuator: 1x, 2x, 3x, 4x

The device integrates a 10-bit high-speed and ultra-low-power general-purpose analog-to-digital converter (ADC). It can operate in unipolar (single-ended) mode and bipolar (differential) mode. ADC has its own 0.9v regulator (LDO), which represents the full-scale reference voltage



2.7. Reference Connection Circuit

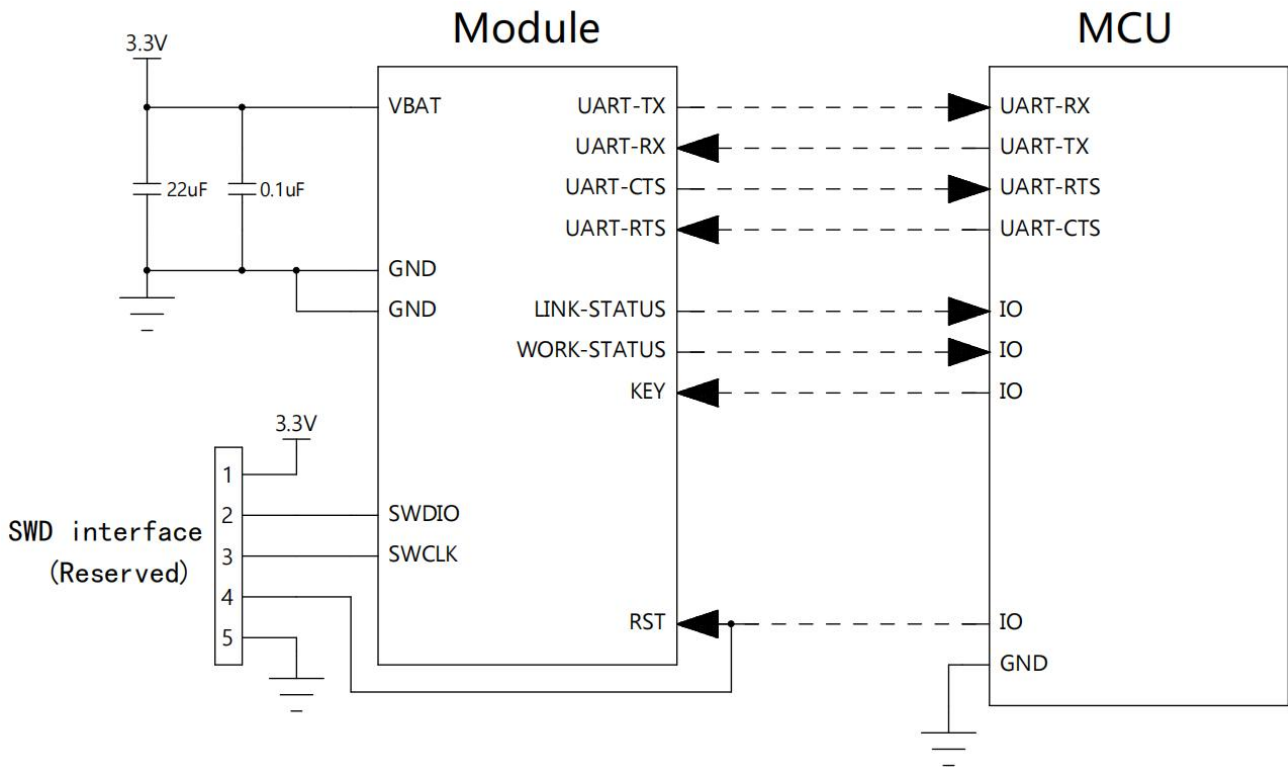

Figure 12: Typical application circuit

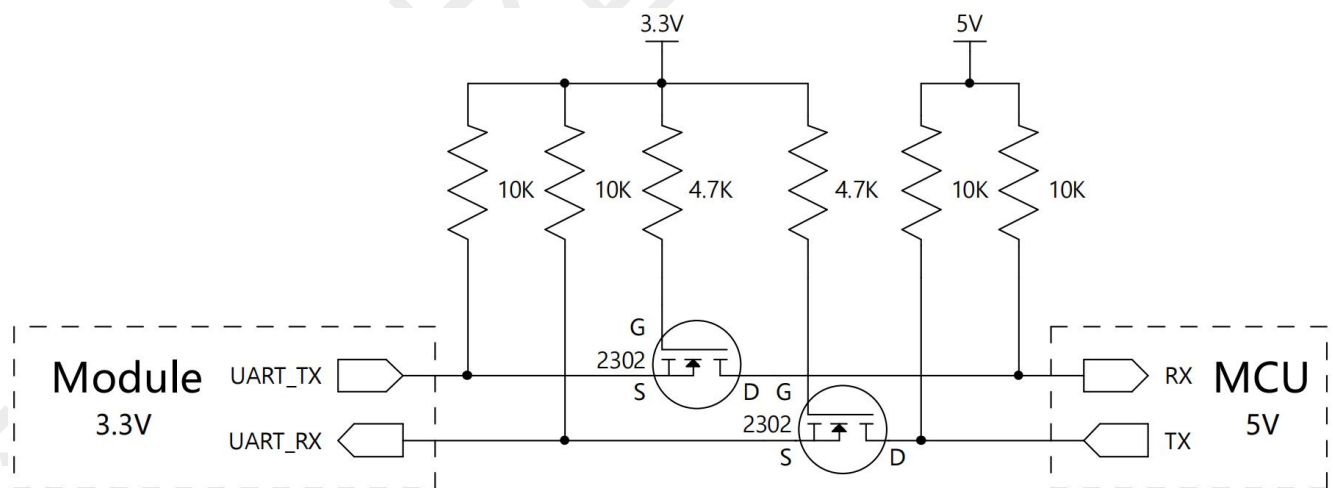

Figure 13: Reference circuit for serial port level conversion

3. Electrical Characteristics & Reliability

3.1. Maximum Rating

The absolute maximum ratings of the supply voltage and voltage on the digital and analog pins of the module are listed below. Exceeding these values will cause permanent damage. The average GPIO pin output current is defined as the average current value flowing through any corresponding pin in a 100mS period. The total average GPIO pin output current is defined as the average current value flowing through all corresponding pins in a 100ms period. The maximum output current is defined as the peak current value flowing through any corresponding pin.

Table 9: Absolute maximum rating table

Absolute maximum rating			
parameter	Minimum	Max	unit
V_{IN} - I/O power supply voltage (VDDIO)	-0.1	+3.6	V
V_{IN} - Analog digital power/voltage (VDD)	-0.1	+3.6	V

Table 10: Working voltage table

Operating Voltage				
parameter	Minimum	Typical	Max	unit
V_{IN} - Core supply voltage (VDD)	2.8	3.3	3.6	V
V_{IN} - I/O power supply/voltage (VDDIO)	2.8	3.3	3.6	V

3.2. Working And Storage Temperature

Table 11: Working and storage temperature table

parameter	Minimum	Typical	Max	unit
Normal working temperature	-40	-	85	°C
storage temperature	-50	-	150	°C



3.3. Power Consumption

Table 12: Power consumption table

mode	state	Current	Unit
Hibernation mode	-	2	uA
Low power mode	not connected	19	uA
	connected	341	uA
Normal working mode	not connected	270	uA
	connected	341	uA
When transparently transmitting data	connected	MIN: 341uA MAX: 986uA	MIN is the power consumption when not sending data MAX is the power consumption when the data volume sent by the module is 10626bytes/s

Remark

The power consumption in the above table is measured at a broadcast interval of 540ms, for reference only. The power consumption of this module in different broadcast intervals is different, the specific power consumption is subject to the actual.

3.4. RF Characteristics

Table 13: RF characteristics table

Function	Value
BLE transmit power	-19.5 ~2.5dBm
BLE sensitivity	-94dBm@0.1%BER

3.5. Static Protection

In the application of the module, due to the static electricity generated by human body static electricity and charged friction between microelectronics, it is discharged to the module through various ways, which may cause certain damage to the module, so ESD protection should be taken

seriously. In the process of R&D, production, assembly and testing, especially in product design, ESD protection measures should be taken. For example, at the interface of the circuit design and the points that are easily damaged or affected by electrostatic discharge, anti-static protection should be added; anti-static gloves should be worn during production.

Table 14: Table of ESD withstand voltage of module pins

Test interface	Contact discharge	Air discharge	unit
VBAT & GND	+4	+8	kV
Main antenna interface	+2.5	+4	kV

4. Mechanical Size And Layout Recommendations

This section introduces the mechanical dimensions of the module, all dimensions are in millimeters; for all tolerances that are not marked, the tolerance is ± 0.3 mm

4.1. Module Mechanical Size

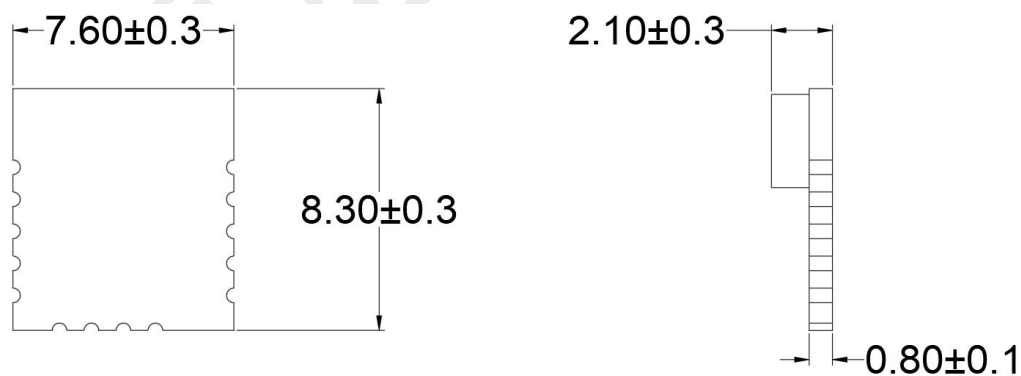

Figure 14: Module top and side dimension drawing

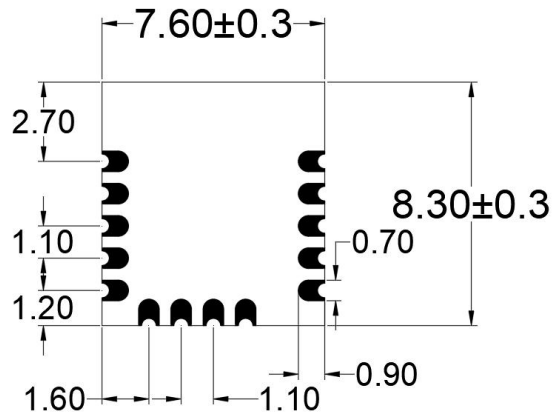

Figure 15: Bottom view size of the module

4.2. Recommend Encapsulation

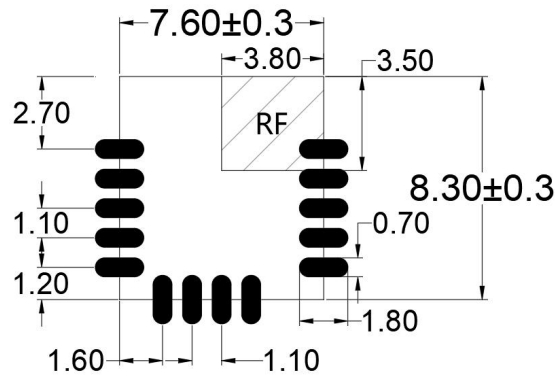

Figure 16: Recommended package dimensions

4.3. Module Top View & Bottom View

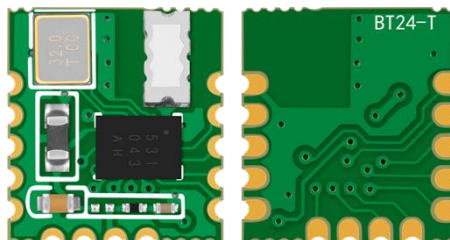

Figure 17: Top and bottom views of the module

Remark

The above picture is for reference only. For the actual product appearance and label information, please refer to the actual module.



4.4. Hardware Design Layout Recommendations

The DX-BT24-T Bluetooth module works in the 2.4G wireless frequency band and uses an on-board antenna. The standing wave ratio (VSWR) and efficiency of the antenna depend on the placement of the patch. Various factors should be avoided as far as possible to the wireless signal transmission and reception. Pay attention to the following What time is it:

- 1、 Avoid using metal for the product shell surrounding the Bluetooth. When using a part of the metal shell, try to keep the antenna part of the module away from the metal part. The metal connecting wire or metal screw inside the product should be as far away as possible from the antenna part of the module.
- 2、 The antenna part of the module should be placed against the edge of the carrier board PCB or directly exposed to the carrier board, and it is not allowed to be placed in the middle of the board, There is at least 5mm of free space in the antenna direction, and the carrier board under the antenna is milled out. Copper and wiring are not allowed in the direction parallel to the antenna.
- 3、 It is recommended to use insulating material to isolate the module mounting position on the substrate, for example, put a whole piece of silk screen at this position (TopOverLay)

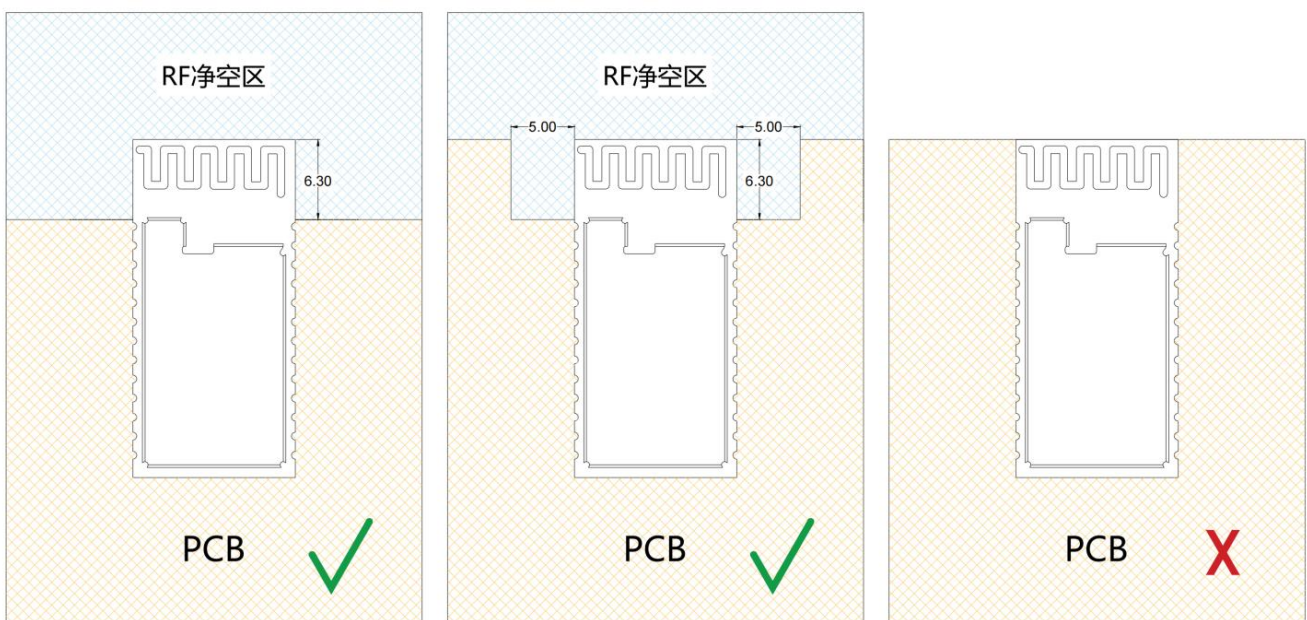

Figure 18: Reference position for module placement



5. Patch Requirements

5.1. Storage Conditions

Modules are shipped in vacuum sealed bags. The humidity sensitivity level of the module is 3 (MSL 3), and its storage must comply with the following conditions:

1. Recommended storage conditions: temperature $23\pm 5^{\circ}\text{C}$, and relative humidity 35~60%.
2. Under the recommended storage conditions, the module can be stored in a vacuum sealed bag for 12 months.
3. Under workshop conditions with a temperature of $23\pm 5^{\circ}\text{C}$ and a relative humidity of less than 60%, the workshop life of the module after unpacking is 168 hours. Under this condition, the module can be directly subjected to reflow production or other high-temperature operations. Otherwise, the module needs to be stored in an environment with a relative humidity of less than 10% (for example, a moisture-proof cabinet) to keep the module dry.
4. If the module is under the following conditions, the module needs to be pre-baked to prevent the PCB from blistering, cracks and delamination that occurs after the module absorbs moisture and gets wet and then solders at a high temperature:
 - Storage temperature and humidity do not meet the recommended storage conditions;
 - The module failed to complete production or storage according to Article 3 above after unpacking;
 - Vacuum packaging leaks, bulk materials;
 - Before module repair;

5.2. Module Baking Treatment

- Requires high temperature baking at $120 \pm 5^{\circ}\text{C}$ for 8 hours;
- The second-baked module must be soldered within 24 hours after baking, otherwise it still needs to be stored in a dry box;



Remark

1. In order to prevent and reduce the occurrence of defective welding such as blistering and delamination caused by damp, strict control should be carried out. It is not recommended to expose to the air for a long time after unpacking the vacuum package.
2. Before baking, take the module out of the package and place the bare module on a high temperature resistant appliance to avoid high temperature damage to the plastic tray or reel; The second-baked module must be soldered within 24 hours after baking, otherwise it must be stored in a dry box. Please pay attention to ESD protection when unpacking and placing the module, for example, wear anti-static gloves.

5.3. Reflow Soldering

Use a printing squeegee to print the solder paste on the screen so that the solder paste is printed on the PCB through the opening of the screen. The force of the printing squeegee needs to be adjusted appropriately. In order to ensure the quality of the module printing paste, the thickness of the stencil corresponding to the module pad part is recommended to be 0.1~0.15mm .

The recommended reflow soldering temperature is 235~250 °C, and the maximum should not exceed 250 °C. In order to avoid damage to the module due to repeated heating, it is strongly recommended that customers re-attach the module after completing the reflow soldering on the first side of the PCB board. The recommended furnace temperature curve (lead-free SMT reflow soldering) and related parameters are shown in the chart below:

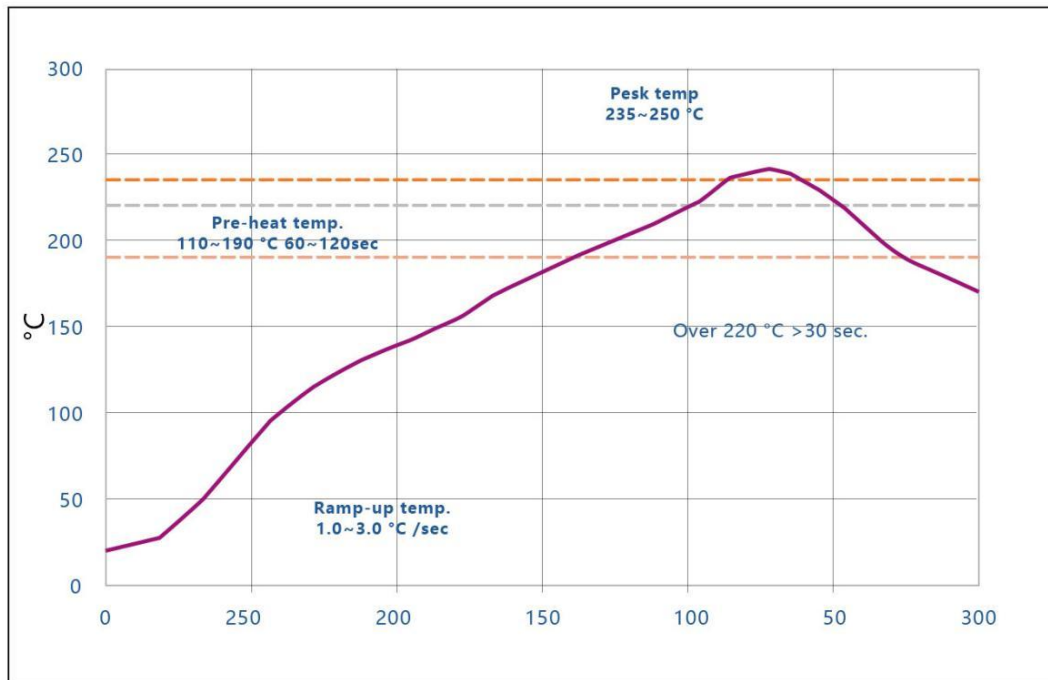

Figure 19: Recommended reflow soldering temperature profile

Table 15: Recommended reflow soldering temperature

Statistics name	Lower limit	Upper limit	unit
Slope 1 (target=2.0) is between 30.0 and 70.0	1	3	Degree/sec
Slope 2 (target=2.0) is between 70.0 and 150.0	1	3	Degree/sec
Slope 3 (target = -2.8) is between 220.0 and 150.0	-5	-0.5	Degree/sec
Constant temperature time 110-190°C	60	120	sec
@220°C Reflow time	30	65	sec
Peak temperature	235	250	Celsius
@235°C total time	10	30	sec

5.4. Packing Specification

The DX-BT24-T Bluetooth module is packaged in a pallet and sealed in a vacuum-sealed bag with a desiccant and humidity card in the vacuum-sealed bag. Each tray is long mm * wide mm * high mm, and 25 modules are placed on each tray. Every 1000 modules are placed in a box with



length 250mm*width 200mm*height 70mm, and each box with length 430mm*width 210mm*height 270mm can hold 5000 modules. The specific specifications are as follows

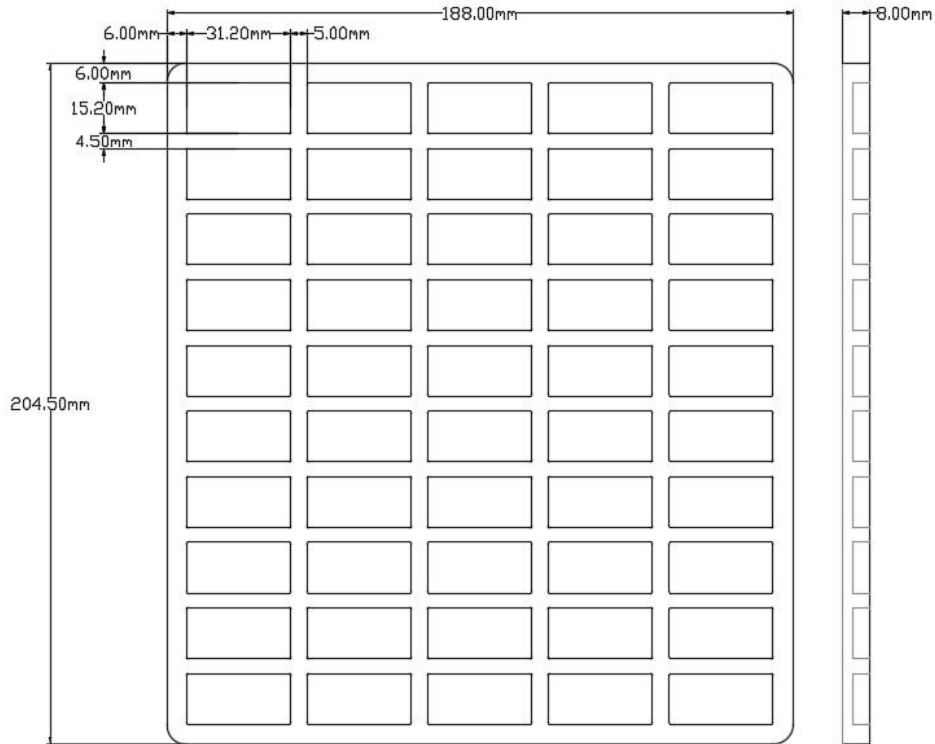

Figure 20: Pallet size (unit: mm)

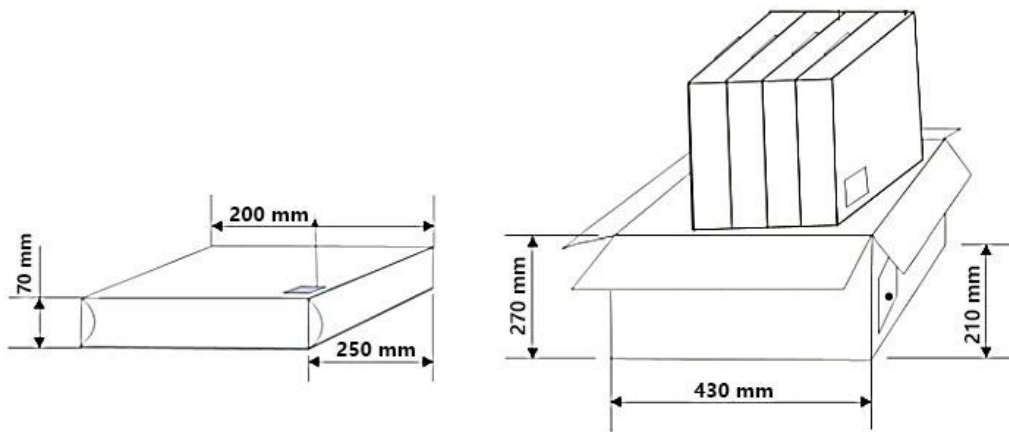

Figure 21: Packing box size (unit: mm)